



Level



Pressure



Flow



Temperature



Liquid  
Analysis



Registration



Systems  
Components



Services



Solutions

Technical Information

## Turbimax CUE21 / CUE22

Turbidimeter for on-line measurement



### Application

On-line continuous monitoring of clean water:

- Drinking water
- Treated process water

### Your benefits

- Versions with white light source and infrared light source available
- Fast and easy calibration
  - Complete primary calibration in less than 5 minutes
  - Verification in seconds
- Reduced calibration costs and quick response times thanks to low volume sample chamber
- Automatic continuous ultrasonic cleaning (Autoclean) increases cleaning intervals dramatically
- Simple modular design
- Easy to use and service
- Affordable thanks to modular microprocessor based technology
- Digital high-speed connections through RS-485 with Modbus

Optional Features:

- Flow chamber for bubble suppression
- Reusable calibration kit

---

## Function and system design

---

### Measuring principle

#### Turbidity measurement

For turbidity measurement a light beam is sent through the medium and is diverted from its original direction by optically denser particles, e.g. solid matter particles.

### Measuring methods

#### 90° WL scattered light method

The measurement uses the standardised 90° scattered light method acc. to U.S. EPA 180.1. The turbidity of the medium is determined by the amount of scattered light. The transmitted white light beam is scattered by the solid matter particles in the medium. The scattered beams are detected by scattered light receivers which are arranged at an angle of 90° to the white light source.

#### 90° NIR scattered light method

The measurement uses the standardized 90° scattered light method acc. to ISO 7027 / EN 27027. The turbidity of the medium is determined by the amount of scattered light. The transmitted light beam with a wavelength in the near-infrared range is scattered by the solid matter particles in the medium. The scattered beams are detected by scattered light receivers which are arranged at an angle of 90° to the infrared light source.

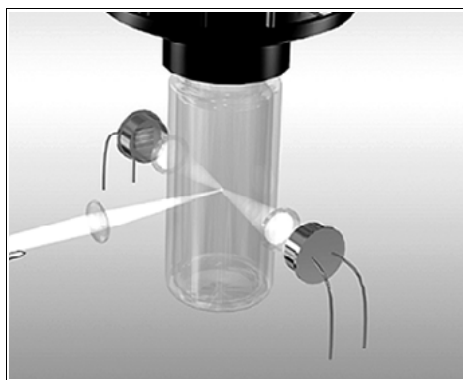

90° scattered light method

### Functions

#### IR or white light measurement

The Turbimax is available as infrared version, CUE21, to meet the design criteria specified in ISO 7027 and DIN 27027. The white light version, CUE22, meets the design criteria on turbidity measurement specified by the US EPA 180.1. Both versions have long life lamps.

#### Backlit LCD

The backlit LCD allows for easy readability in low light or no light conditions. The backlight is intended for continuous operation. The brightness can be adjusted in a menu in the CONFIG mode.

#### Vapor purge

The Turbimax is equipped with a continuous vapor purge system. A replaceable desiccant pouch in the lower portion of the instrument dries the air. System heat is used to warm the air. A fan inside the instrument continuously circulates heated dry air around the optical well and the flow through cuvette. This eliminates the need for a dry purge line.

#### Alarms

The Turbimax provides two relays that are designed to operate as two independent, programmable alarms. The alarms can be configured to activate when the measured turbidity level is higher or lower than the programmed alarm level for a given period of time. The alarm function also allows to set delay times.

#### Ultrasonic cleaning

This option is used to continuously clean the flow through cuvette. It is not intended to clean already dirty cuvettes or to replace manual cleaning entirely. The system will increase the time between cleanings dramatically. Please note that the system requires the use of a special cuvette.

### RS-485 outputs

Turbimax has the capability to operate in two different RS-485 modes, a simple communication mode and Modbus protocol communication.

- The simple communication mode provides communication over programs such as the HyperTerminal that is included with most Microsoft Windows packages. You can also use Visual Basic or other programs. The default communication parameters are 8 bits, no parity and 1 stop bit.
- Modbus protocol communication is available for all models. The Modbus information is covered in a separate manual.

### Flow controller

The flow controller limits the flow, in high-pressure systems, to safe flow limits of less than 1 liter/minute.

### Measuring system

The Turbimax CUE21 / CUE22 measuring system comprises:

- Turbimax turbidimeter with installed cuvette and desiccant pouch
- Connecting tubing with
  - fittings for flow through assembly
  - shutoff clamp
  - backpressure valve
  - drain vent screw (in pressurized systems)
- Sensor interconnect cable

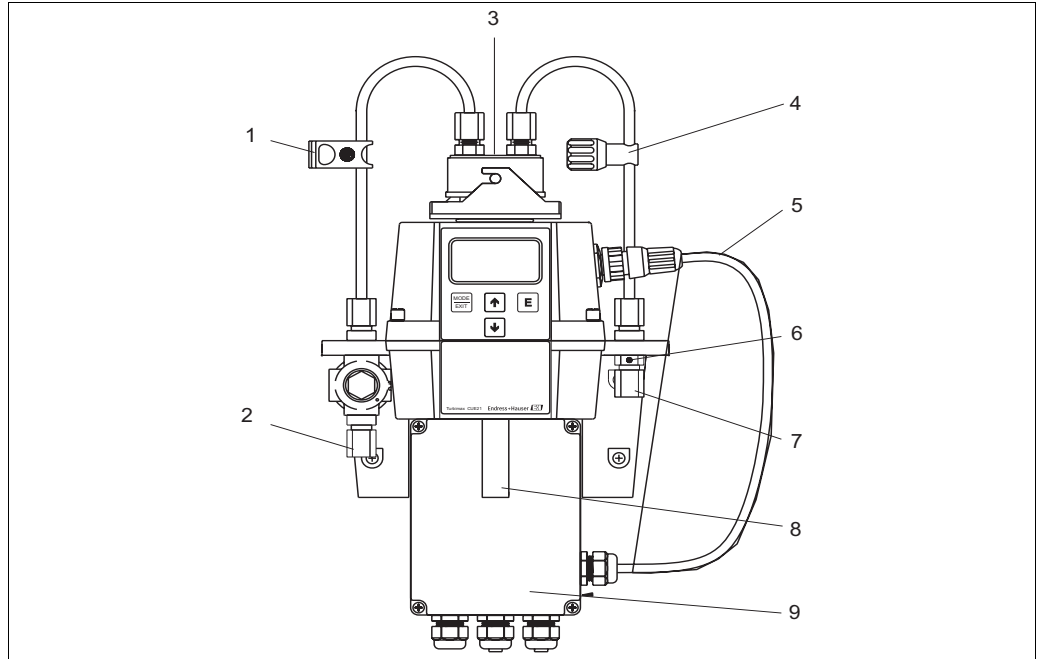

*Turbimax CUE21 system (example)*

- |   |   |   |  |
|---|---|---|--|
| 1 | Shutoff clamp   | 6 | Drain vent   |
| 2 | Intake tubing connection (for OD 8 mm (0.31"), ID 4.75 mm (0.19") tubing) | 7 | Drain tubing connection (for OD 8 mm (0.31"), ID 4.75 mm (0.19") tubing) |
| 3 | Flowhead  | 8 | Emergency drain  |
| 4 | Backpressure valve  | 9 | Field terminal box   |
| 5 | Sensor interconnect cable   |   |  |

## Input

### Measured variables

Turbidity

### Measuring range

CUE21: 0 to 1000 NTU /FNU  
CUE22: 0 to 100 NTU /FNU

## Output

<b>Output signal</b>	4 to 20 mA, galvanically isolated	
<b>Signal on alarm</b>	2 mA in case of an error	
<b>Load</b>	max. 600 $\Omega$	
<b>Communications port</b>	Bi-directional RS-485, Modbus optional	
<b>Relays</b>	Switching voltage: Switching current:	max. 240 VAC max. 2 A
<b>Limit value and alarm functions</b>	Setpoint adjustment: CUE21: CUE22: Alarm delay:	0 to 1000 NTU 0 to 100 NTU 0 to 30 s

## Power supply

### Electrical connection

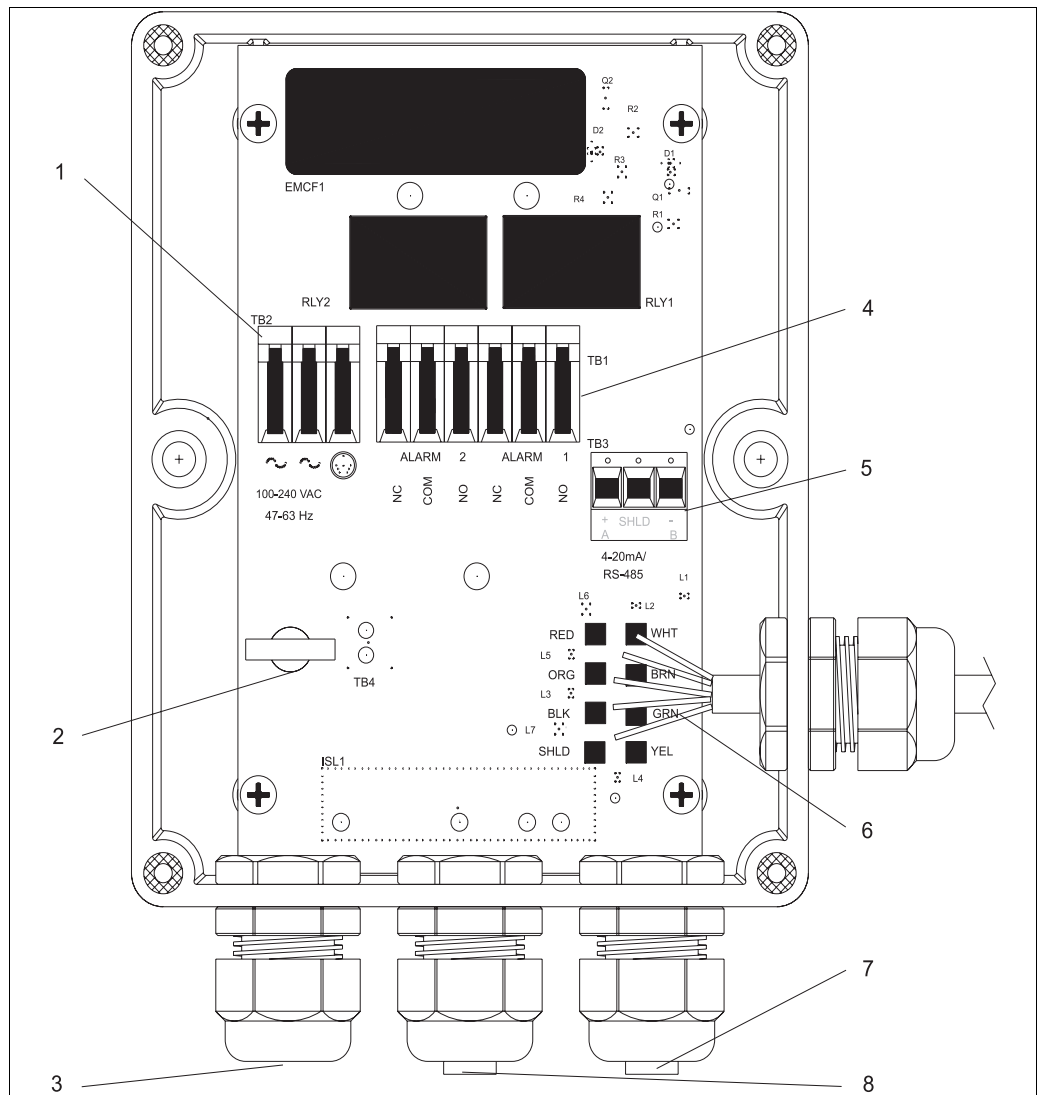

#### Field terminal box

- |   |                                   |   |                                   |
|---|-----------------------------------|---|-----------------------------------|
| 1 | Power supply terminal block       | 5 | 4 to 20 mA / RS485 terminal block |
| 2 | Power cable strain relief         | 6 | Sensor wiring                     |
| 3 | Power cable gland                 | 7 | 4 to 20 mA / RS485 cable gland    |
| 4 | Alarms terminal block, 240 VA, 2A | 8 | Alarm cable gland                 |

a0003464

**Power supply** 100 to 240 VAC, 47 to 63 Hz, 80 VA switching power supply

## Performance characteristic

<b>Response time</b>	adjustable 1 to 100 % (approx. 5 to 500 seconds) CUE21: 0 to 1000 NTU CUE22: 0 to 100 NTU	
<b>Reference temperature</b>	25 °C (77 °F)	
<b>Resolution</b>	0.0001 NTU (below 10 NTU)	
<b>Maximum measured error</b>	below 40 NTU: above 40 NTU:	±2 % of reading or ±0.02 NTU whichever is greater ±5 % of reading
<b>Repeatability</b>	±1 % of reading	

## Installation

### Wall mounting

Turbimax CUE21 / CUE22 is recommended for indoor use.

When mounting the instrument note the following:

- Check that the temperature does not exceed the maximum permitted operating temperature range (0 to 50 °C (32 to 122 °F)).
- Leave a free area of approx. 0.20 m (8.00") above the instrument. This will ensure enough room for calibration and cuvette maintenance.
- Mount the instrument as close as possible to the sampling point to ensure a quick response time (within 2 to 3 m (6 to 10 ft)).

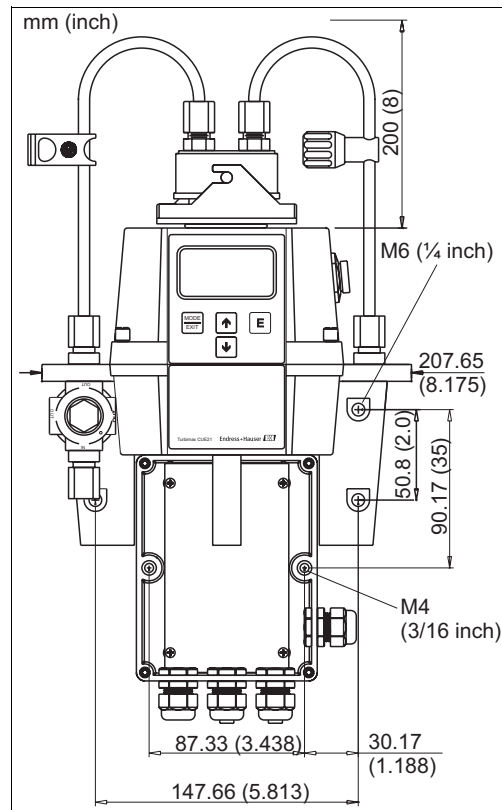

Mounting dimensions front view

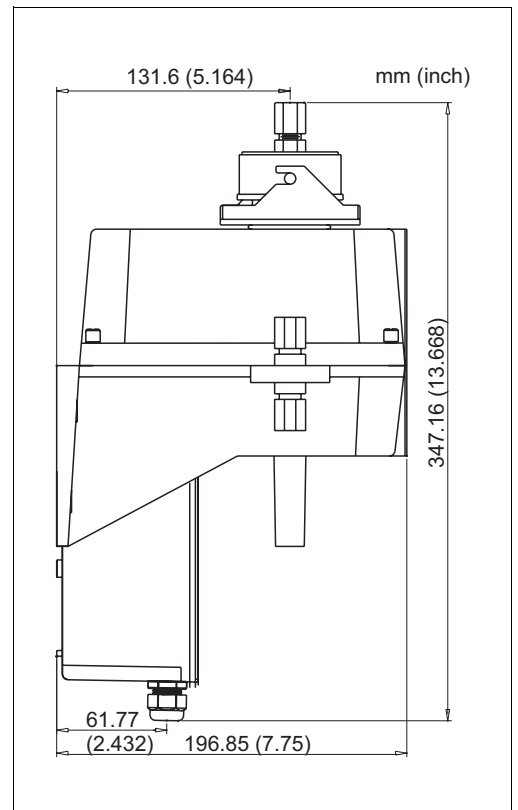

Mounting dimensions lateral view

---

## Environment

---

<b>Storage temperature</b>	-20 to +60 °C (-4 to +140 °F)
<b>Ingress protection</b>	IP 66 / NEMA 4x
<b>Insulation rating</b>	Double insulated, pollution degree 2
<b>Overvoltage protection</b>	Category II
<b>Relative humidity</b>	max. 95%, non-condensing
<b>Altitude</b>	up to 2000 m

## Process

---

<b>Process temperature</b>	1 to 50 °C (34 to 122 °F)
<b>Medium temperature range</b>	1 to 50 °C (34 to 122 °F)
<b>Process pressure</b>	max. 13.78 bar (200 psi) controlled by integral pressure regulator
<b>Flow rate</b>	0.1 to 1 liter/min. (0.026 to 0.26 US.gal/min.)

## Mechanical construction

---

<b>Dimensions</b>	H x W x D: 347.16 x 207.65 x 196.85 mm (13.668" x 8.175" x 7.750")
<b>Weight</b>	2 kg (4.4 lbs.)
<b>Materials</b>	Housing: ABS Flow-through head: Nylon Sample cuvette: Borosilicate glass Sample cuvette seal: Silicon Flow-through fittings: Polypropylene Flow-through lock down pins: Stainless steel (AISI 304 or AISI 303) Inlet tube: Stainless steel (AISI 316)
<b>Light source</b>	Turbimax CUE21: Infrared LED, 860 nm Turbimax CUE22: White light Tungsten lamp, ~600 nm, 2250 °K

## Human interface

### Display and operating elements

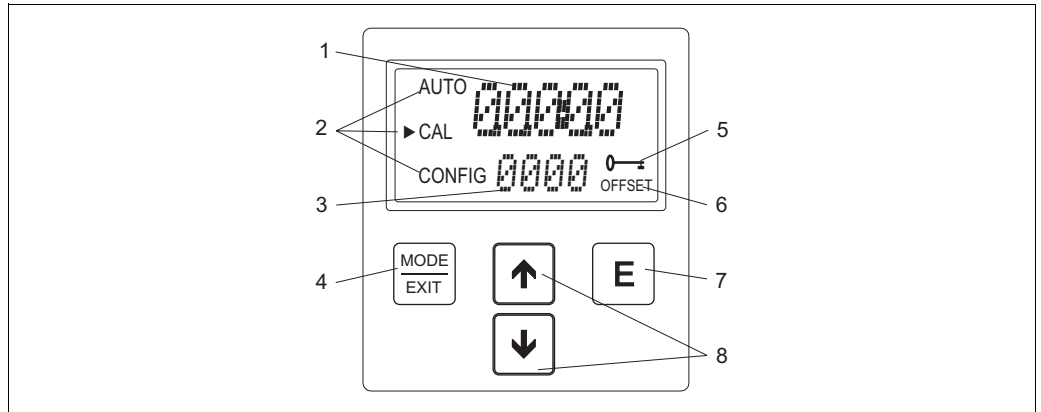

#### Display and operating elements

- 1 Display of turbidity levels and user guidance in configuration
- 2 Mode arrow to indicate instrument operating mode; AUTO (measurement), CAL (calibration), CONFIG (configuration)
- 3 Display of error messages and user guidance
- 4 MODE/EXIT key used to cycle between the three instrument operating modes
- 5 Icon indicating the use of access code
- 6 Icon indicating OFFSET mode
- 7 **E** key to confirm an option or mode that is highlighted or chosen
- 8 **↑** **↓** keys used to change settings

## Certificates and approvals

### CE symbol

#### Declaration of conformity

The product meets the legal requirements of the harmonized European standards.  
The manufacturer confirms compliance with the standards by affixing the **CE** symbol.

### ETL approval

- Tested and passed ETL (tested to UL3111-1), 1<sup>st</sup> Edition 1994, w/Bulletin June 5, 1996
- Tested and passed ETLc (tested to CSA C22.2#1010.1-92)

### EMC compatibility

Interference emission and interference immunity complies with EN 61326: 1997 / A1: 1998

## Ordering information

### Turbimax CUE21 compact device, infrared

Power supply	
A	100 to 240 VAC
Output	
1	4 to 20 mA or RS-485
Version	
A	Standard
CUE21-	complete order code

### Turbimax CUE22 compact device, white light

Power supply	
A	100 to 240 VAC
Output	
1	4 to 20 mA or RS-485
Version	
A	Standard
CUE22-	complete order code

## Scope of delivery

The scope of delivery comprises:

- 1 Turbimax CUE21 / CUE22 turbidimeter
- 1 Field terminal box
- 1 Flow through assembly
- 1 Desiccant pack
- 1 Cuvette (single pack)
- 1 Tubing kit including
  - 1 shutoff clamp
  - 1 backpressure valve
  - 2 connecting tubes with fittings for flow through assembly
  - 1 drain vent screw (used in pressurized systems)
- 1 Operating Instructions BA395C/07/en

## Accessories

---

### Calibration solutions

Calibration kit CUE21 / CUE23 / CUE24, full range

- 0.02 NTU
- 10.0 NTU
- 1000 NTU

Order no.: 51518580

Calibration kit CUE22, full range

- 0.02 NTU
- 10.0 NTU
- 100 NTU

Order no.: 71030102

---

### Ultrasonic cuvette

- Replacement cuvette with ultrasonic transducer allowing to use the ultrasonic cleaning feature
- Order no.: 51518576
- 

### Flow chamber

- Flow chamber CUE21 / CUE22 for air bubble suppression
- Order no.: 51518575
- 

## International Headquarters

Endress+Hauser  
GmbH+Co. KG  
Instruments International  
Colmarer Str. 6  
79576 Weil am Rhein  
Deutschland

Tel. +49 76 21 9 75 02  
Fax +49 76 21 9 75 34 5  
www.endress.com  
info@ii.endress.com